

WILLIAM YEOWARD

...collected

a collection of
historical furniture
revisited



www.williamyeoward.com

WILLIAM YEOWARD

.....collected

a collection of historical furniture revisited

"William Yeowardcollected" is exactly that! A collection of furniture both loved and admired over some thirty years of furniture making and decorating.

"Lately I have found it very annoying that the beautiful pieces of furniture that I have eyed and hankered after have become both extremely scarce and, when available, well beyond my pocket! I decided some time ago that I would put the wheels in motion to find a way of reintroducing some of these wondrous pieces to the market".

"To see furniture being made at the bench using the same techniques as when first manufactured made me very happy and confident that I could produce a collection my clients would be happy with."

This first catalogue of pieces for William Yeowardcollected will be an assortment of favourite, admired and above all useful furniture that will stand alone in interiors of many different styles and references. Consoles, benches and chairs, desks, beds, cupboards, bureaux, dining and side, occasional and coffee tables are just a handful of pieces that are mixed together in a vibrant and enticing way finished with a selection of exciting materials and a great deal of care. Woods of every colour and temperament are mixed with marble and faux marble, brass and parquetry, carving and turning all to give a diversity rarely seen today.

The catalogue will be photographed in interiors of many different periods and scales with these illustrative images prepared to inspire and help to give confidence and variety in the way these beautiful shapes can be used.

With over eighty pieces and twenty finishes William Yeowardcollected is certainly worth a good look and may yet become another of William's regular introductions.



Y4078 Corwen Centre Table
Washed Oak 52" x 45" x 31 1/4"

The interior designer in me loves the idea of using a Corwen centre table as precisely that. An hexagonal faux marble painted top and the dirty gilt applied to the washed oak base, makes this piece somewhat of a spectacle. Use it as a centerpiece in the grandest of schemes and be amazed by the personality of this piece.



Y4006 Aveburn Arm Chair
Greyed Fruitwood
21 3/4" x 21 3/4" x 38"

Aveburn arm chair seen in fruitwood is a replica of a country chair from the 1790s. This delightful piece is steeped in classicism and has been carefully crafted with a rush seat. Great for dining or using in halls, kitchens or even, as I do, a bedroom.



Y4079 Lacock Dining Table
Washed Oak & Gilt 70 3/4" x 70 3/4" x 29 1/2"

The Lacock dining table, which I have taken from a table with a much smaller base now, happily seats ten. Its scroll foot and book-matched veneered top, finished in washed oak with touches of gilt, makes it the enviable combination of smart and grand but not traditional.

Y4008 Aveburn Side Chair
Greyed Fruitwood
19 3/4" x 21 3/4" x 38"

Aveburn side chair seen in fruitwood is a replica of a country chair from the 1790s. This delightful piece is steeped in classicism and has been carefully crafted with a rush seat. Great for dining or using in halls, kitchens or even, as I do, a bedroom.



Y4072 Dudley Console
Rich Mahogany 50 3/4" x 24" x 36"

I have always loved a little rich mahogany detail in a decorative scheme. Our Dudley console together with the Pennstewart mirror looks marvellous in a traditional hall or dining room. I decided to sneak in a drawer so that the console table becomes more flexible and useful. It is worth noting the beautiful proportions of the leg on this piece.



Y4074 Pennstewart Mirror Round
Rich Mahogany 45" x 45" x 1 3/4"

This round Pennstewart mirror has a strangely contemporary feel for such a traditional piece. It is light and reflective, mainly due to the fact that the lens can be seen through the frame. I find it a perfect proportion to go above a chimney piece in a dining or living room.



Y4056 Hemsley
Multi Faux Marble & Black 25 3/4" x 20" x 27 3/4"

I let my imagination run riot when deciding on the finish of this Hemsley table. The top being beautifully painted by a true artist in brightly coloured faux marble contrasts beautifully with the base in a wonderful blackened finish. The gilded band around the top only serves, in my humble opinion, to frame the exquisite detail.



Y4047 Godwyn Table
Washed Oak 32¾" x 21¼" x 28¼"

The Godwyn side table is a piece in this collection which I truly marvel at. The amusing fox heads, hand-carved amongst leaves and foliage, make for a pleasing and yet frivolous atmosphere. The front of the table, being a drawer, makes this piece suitable to be placed by the sofa or by the bed. It's important to occasionally add humour to a decorative scheme.



Y4045 Godwyn Table
Country White
32¾" x 21¼" x 28¼"



Y4046 Godwyn Console
Greyed Oak 63½" x 25¾" x 30"

Our Godwyn console table, taken from its smaller friend, seems to me to fit perfectly behind the sofa, on which to place a pair of beautiful lamps and a large tray of cocktails. Again, the drawer of the table is lined in our signature polka dot. I think a little fantasy in any decorative scheme always lightens the mood.



Y4069 Armadale Console
Washed Oak 50" x 18" x 32"

Armadale is all about 1940s American "fancy". Its silly, frilly and very very pretty!

I imagine this piece to be in a guest house laden with cocktail ingredients or in a pool house doing much the same job. It comes from my imagination and has nothing to do with anything, save that I love it!



Y4067 Arlington Mirror
Washed Oak 28" x 55" x 1½"

Our Arlington mirror is nothing short of amusing. Shown here is a washed oak finish, this piece seems timeless and could easily find itself being used in a pool house or a smart bedroom above our Armadale console.



Y4070 Dalkeith Table
Washed Oak 36" x 36" x 32½"

The Dalkeith table is a masterstroke in carving. The hand-carved oak base, which has been fluted, chiselled and sanded, supports the amusing top with curled edge and inset with white Carrara marble. I would love to use this in a foyer or a loggia.





Y4017 Kilkenny Chair
Country White 22" x 23" x 37 3/4"

Kilkenny chair so named because I found this perfect multi-purpose comfortable armchair on a trip to Ireland. So often a good easy to use armchair is needed when decorating a house. I would use this in a kitchen at the table, as a pair each side of a console, in the hall or even at my desk. Constructed by hand in acacia and finished in our country white paint.



Y4015 Bellingham Double Bench
Country White 60" x 16" x 25 1/4"

Bellingham double bench constructed of acacia and finished our country white paint with a fine rush seat is perfect at the foot of a bed. Taken from a family piece this bench and the single version has many uses. Great in front of the sofa and also in the hall or even on a landing.



Y4016 Bellingham Single Bench
Country White
38" x 16" x 25 1/4"



Y4057 Alnwick Bureau
Oak & Paint 56 1/2" x 23 1/4" x 99"

My Alnwick bureau has been moved so many times and been used in so many different decorative schemes that I struggle to remember exactly when it came into our house. The exaggerated cornice and the beautifully rubbed back white exterior help frame the pretty blue interior with its balustrade and its little drawers. Not only is this bureau extremely handsome, it is also madly useful as a place for storage and writing letters even on a laptop.



Y4071 Maran Console
Painted & Washed Oak
48 1/4" x 26 1/4" x 34"

The Maran console table has the leg of a champion racehorse. Slender, elegant and perfectly turned with its painted frieze and oak planked top, this table can be used in all manner of locations.



Y4012 Glendurgan Sofa
Washed Oak 63 1/2" x 22 3/4" x 37"

Glendurgan sofa finished in washed oak is a marvellous piece for use in the hall or even on the Loggia. The sofa is light, elegant and above all very smart. I might put one at the bottom of my bed or in the cloakroom!

Y4010 Glendurgan Arm Chair
Washed Oak 23 1/2" x 22 3/4" x 37"

Glendurgan Chair shown in a washed oak finish with finely rushed seat. This chair has been constructed in a traditional way. The design being inspired by the English Arts and Crafts period.



Y4058 Tenbury Games Table
Oak & Marquetry 31 1/2" x 31 1/2" x 28 1/2"

One can only marvel at the humour of the Tenbury games table with its stack of books, its secret drawers and chessboard top. I really feel that no library should ever be without one.



Y4066 Daphne's Cupboard
Washed Oak & Paint 40" x 21 1/4" x 95"

Daphne's cupboard is based on a piece that one of my distant relations owned and in which she kept her collection of crystal. I find this interesting as my love of crystal must have come from admiring the pieces that were stored and presented in this cupboard. The dragged blue interior finish is so similar to the cupboard that Daphne owned, while the exterior has been given a sharp modern look by being made in beautiful natural washed oak topped with a dab or two of gilt.





Y4029 Aberfoyle Chest of Drawers
 Greyed Fruitwood 43¼" x 19¾" x 35"
 With a distinctive hand-cut "castellated" trim and a most original drop handle Aberfoyle is not just a piece of furniture but a statement.



Y4037 Allerdale Console
 Greyed Fruitwood 48½" x 16¼" x 33½"
 This Allerdale console is still in my London Apartment and after 35 years; it still gives me pleasure.

Y4024 Purbeck End Table
 Greyed Fruitwood 35½" x 25½" x 30"
 The Purbeck table in grey mahogany from our entry in our London apartment has always been thoroughly admired and I dare say envied!



Y4049 Strathraven Dressing Table
 Ebonised Mahogany 50" x 24" x 30"
 Strathraven was a house where an old aunt lived years ago and in it she had bobbin furniture that had been clumsily ebonised. I thought it would be fun to do my version of it complete with polka dot drawer linings made by hand of marquetry.



Y4013 Halwell Chair
 Greyed Fruitwood 24¼" x 24¾" x 34¾"
 We have, in the past, used the Halwell chair at a dining or breakfast table. We now use it as a set of four from which to play cards.



Y4020 Gunby Chair
 Grey Fruitwood 22½" x 23¾" x 37 3/8"
 Seat height 19¼"
 Gunby dining chair is smart comfortable and taken from one in my collection purported to be by Mr Hepplewhite!

Y4031 Pilsden Dining Table
 Fruitwood 70¼" x 70¼" x 29½"
 Seat height 19¼"
 Pilsden dining table was my very first dining table. I felt lucky when I found this 19th century fruitwood table that sat 7 perfectly! I have expanded it slightly to accommodate 8 to 10 people. The patina is as the original.



Y4021 Gunby Arm Chair
 Grey Fruitwood 23¾" x 23 7/8" x 37 3/8"
 Seat height 19¼"



Y4027 Tomarton End Table
 Greyed Fruitwood 33" x 17¼" x 28¾"
 The Tormarton three tier end table is probably one of the first pieces I ever bought for my house! Shown here with the drawer lined in our signature polka dot the Tormarton table really looks the part.



Y4019 Kilkenny Chair
 Greyed Fruitwood 22" x 23" x 37¾"
 Kilkenny chair so named because I found this perfect multi-purpose comfortable armchair on a trip to Ireland.



Y4065 Havelock Table
 Kitchen Oak 65¼" x 65¼" x 31"
 Our Havelock table is a marvellous piece in majestic oak. The pedestal, which I took from a newel post for the north of England, is really the point of this substantial table. Scallops around the edge and at the base give the table an elegance that it otherwise might not have.





Y4081 Elgin Bookcase

Washed Oak & Brass 48" x 16" x 90"

In my grandfather's library, a pair of Elgin bookcases flanked the entry door with their dirty ochre interiors and their washed oak panels, they certainly produced the perfect spot for storing some of his books. Trimmed with brass and locked with a key, this delightful piece would look equally at home as a china closet.



Y4013 Halwell Chair

Grey Fruitwood 24¼" x 24¾" x 34¾"

Halwell Library chair was taken from a C19th century original. This great comfortable but compact chair has been used in our library at home for many years and comes into its own as a set of four from which to play cards. Upholstered back and seat with a fruitwood frame makes this piece both durable and practical. We have, in the past, used the Halwell chair at a dining or breakfast table.



Y4014 Coniger Chair

Grey Fruitwood
25½" x 27" x 37½"

Coniger upholstered chair has a mid century almost Scandinavian feel to it. A great small armchair that works in city apartments or modern country houses. I use mine alongside other mid century inspired pieces.



Y4080 Langholm Desk

Washed Oak & Brass
68" x 33" x 29½"

Our Langholm desk belonged to my grandfather. I remember this desk piled with papers and a half-lit pipe smouldering in the ashtray. My grandfather never did anything he didn't have to do, so answering correspondence was not on top of his list. With its cushioned doors and brass inlay, the Langholm is certainly a masculine piece of furniture.



Y4064 Hawford Dining Table

Kitchen Oak
Open: 139¾" x 43¾" x 30"
Closed: 99½" x 43¾" x 30"

The Hawford kitchen table has been sat at by my family for almost two generations. I can remember my mother making bread at this table while we experimented as chefs turning our hand to making our first cake. The finish that I choose to call kitchen oak is exactly that, a lovely solid plank of oak coloured to resemble the original 19th century table. We have made one modification in that this table extends to allow even more friends to join together and have fun.



Y4062 Leyburn Mini Table

Fruitwood & Marquetry
19¼" x 13¾" x 17"

The Leyburn with its marquetry top, again inspired by the Swedish movement, is made of grey acacia and the design placed on the top surface is taken by one of my vintage fabrics. I find it very exciting to use marquetry in this way.

Y4061 Leyburn Coffee Table

Fruitwood & Marquetry
49¼" x 30¾" x 19"





Y4023 Eden Console Table
Ebonised Oak with Marble
68½" x 27¼" x 30"

Eden console table from George III period has lived in our hall at home for as long as I can remember. With a great clawed foot and perfect proportions it can easily be put behind a smart sofa and used as a drinks table. Made from oak and finished either in an ebonised finish or a limed rubbed effect and topped with marble the Eden table is to my mind quite perfect



Y4085 Wickens Mirror
Faux Bronze Finish 31½" x 31½" x 2¼"

The Wickens mirror in faux bronze mirror sparkles in any hall dining room or living room that it is placed. It is smart, strong and quite contemporary.



Y4084 Chirk Mirror
Faux Bronze Finish 28½" x 41¼" x 2"

The Chirk mirror in a faux bronze finish was inspired by the trim of the Aberfoyle chest of drawers. I wanted something to sit above the chest that would interpret but not match.



Y4009 Aveburn Chair
Greyed Charcoal Fruitwood 19¾" x 21¾" x 38"

Aveburn side chair seen in greyed charcoal fruitwood is a replica of a country chair from the 1790s. This delightful piece is steeped in classicism and has been carefully crafted with a rush seat. Great for dining or using in halls, kitchens or even, as I do, a bedroom.



Y4022 Eden Console Table
Greyed Oak with Marble Top
Framed in Distressed Brass
68½" x 27¼" x 30½"



Y4083 Keswick End Table
Bronzed Finish 24" x 24" x 26"

The Keswick end table in an antique bronze finish with its smart glass top is the answer to a square armed casual sofa. Pop a lamp on the top and admire the perfect result.



Y4007 Aveburn Arm Chair
Greyed Charcoal Fruitwood
21¾" x 21¾" x 38"

Aveburn arm chair seen in greyed charcoal fruitwood is a replica of a country chair from the 1790s. This delightful piece is steeped in classicism and has been carefully crafted with a rush seat. Great for dining or using in halls, kitchens or even, as I do, a bedroom.



Y4077 Fylde Console
Dark Mahogany with Marble Top
52" x 19¾" x 34"

Our Flyde console is a magnificent example of mid 19th century piece masquerading as its 18th century original. In an ebonised mahogany finish, topped with a lovely slab of Carrara marble, this piece with its carved foot is both elegant and practical.



Y4082 Keswick Coffee Table
Bronzed Finish 60" x 40" x 18"

The Keswick coffee table in an antique bronze finish, in my mind, has everything that is required for modern living. It is strong enough to be piled with magazines and books and doesn't mind being used as a low dining table.





Y4076 Heathcliff Console
 Ebonised Mahogany with Parquetry top
 62¼" x 22" x 34"
 The Heathcliff console shown in ebonised mahogany has sadly never been in my collection but I have admired a similar one from afar! I thought how interesting it would be to replace the original plank top with parquetry.
 The result was sublime and now I am planning on building a space for one in my country house!



Y4001 Bodiam Arm Chair
 Greyed Oak 21¾" x 23" x 37½"
 This Bodiam armchair constructed of greyed oak and taken from an early C19th painted piece at home. This chair has been given a modern finish. Fine hand rushing and plenty of care makes it charming. Bodiam is also strong and durable and can be used in kitchens and dining rooms.



Y4035 Overbury Breakfast Table
 Greyed Oak 54" x 54" x 29½"
 The Overbury table is just so useful. We had the original in our nursery as children and used to take breakfast off it with our nanny. It's a great size and the finish of greyed oak and the use of a crown cut oak top has given it a wonderful organic and rather timeless feel. Once I had seen the original sample I decided we must make it in two sizes.



Y4003 Bodiam Side Chair
 Greyed Oak 21¾" x 23" x 37½"
 This Bodiam side chair constructed of greyed oak and taken from an early C19th painted piece at home. Bodiam is also strong and durable.



Y4041 Artaross Console Table
 Greyed Oak 50½" x 19½" x 34"
 My Artaross Console Table, which we have made in both grey crotch mahogany and greyed oak, as seen here, has drawers lined in my signature woad polka dot marquetry. This table has been utterly and totally invented! Given my fancy for the gothic, it seemed amusing to make a console table for our dining room that could work alongside the Longwood dining table.

Y4040 Longwood Extending Table
 Greyed Oak - Closed 54" x 54" x 30" Open 54" x 76½" x 30"
 The original Longwood table is made of 19th century mahogany and sits at a window in my gothic country house. I fancy that I have an urge for elegant simplicity so we developed this centre table in greyed oak. The detail is a masterstroke and the proportion sublime.
 I love it so much that now we have developed this expanding version on which to take supper.



Y4033 Yarne Table
 Greyed Oak 29½" x 19¼" x 27½"
 My Yarne table in greyed oak has been a firm favourite for as long as I can remember! I lent it to my brother who lives in a house on the coast and it looks so well there. I have modernised the drawer interior by lining it in our signature woad coloured polka dot.



Y4025 Purbeck Console
 Greyed Oak with Marble Top
 66¾" x 25½" x 34½"
 The Purbeck console table with its distressed brass banded marble top looks great in a living room from which to serve cocktails. This piece derived from the original Purbeck table which I have owned for more than 20 years is not only smart but unique! Try finding another!



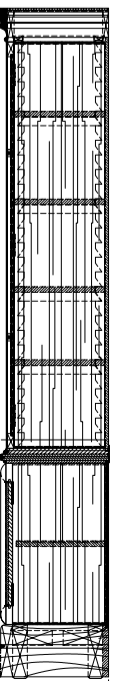
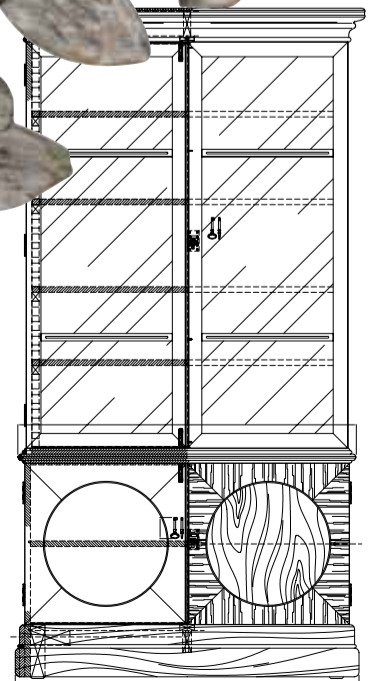
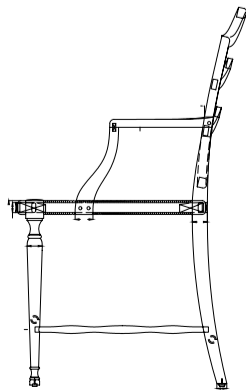
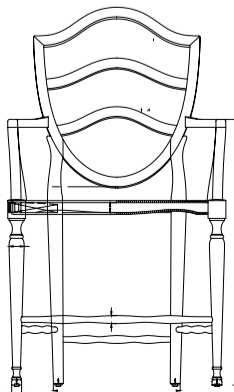
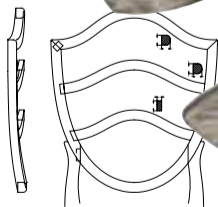
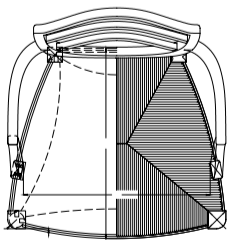
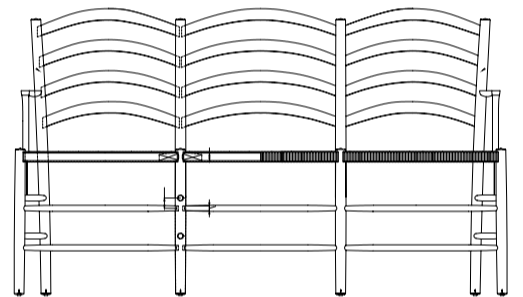
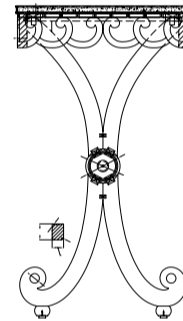
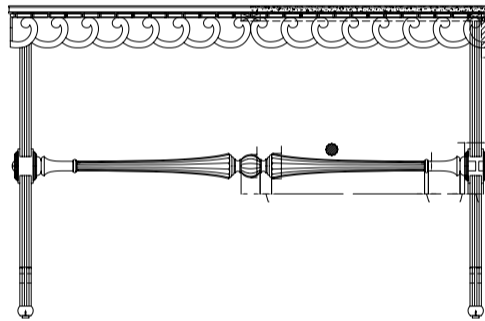
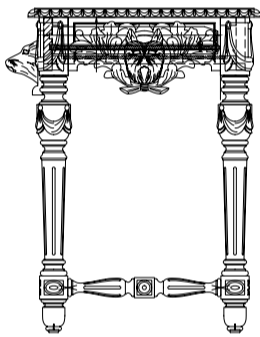
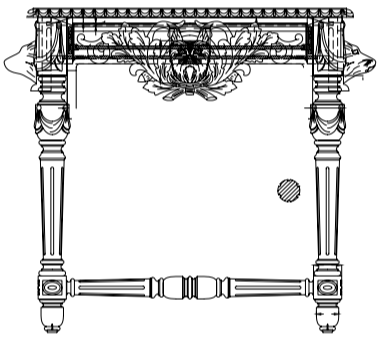
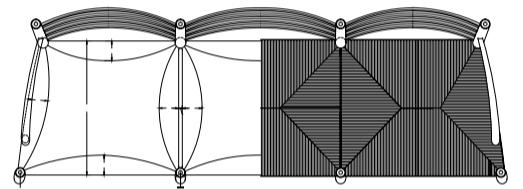
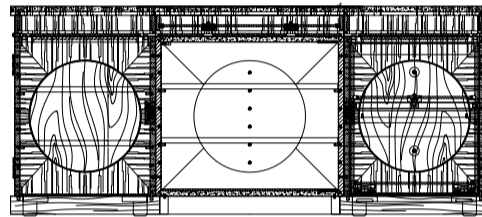
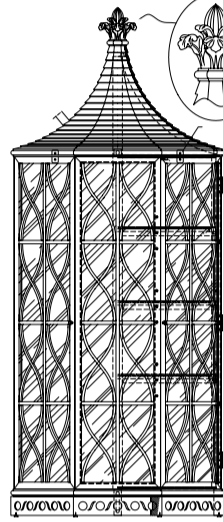
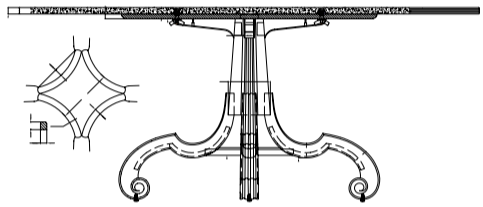
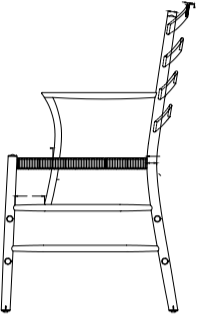
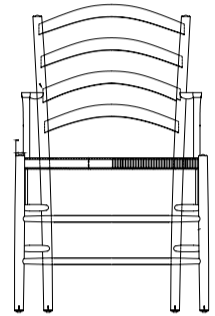
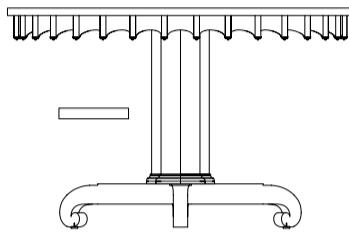
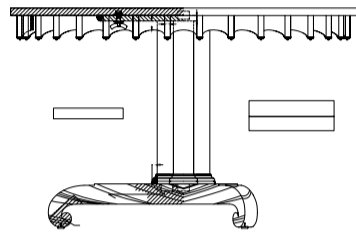
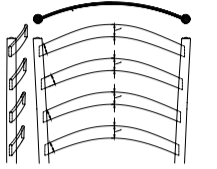
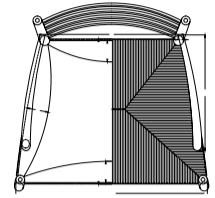
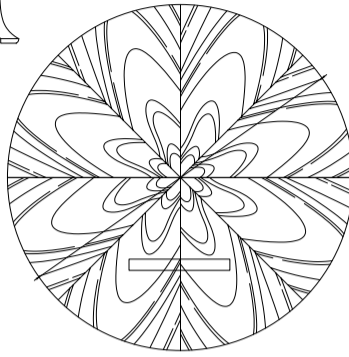
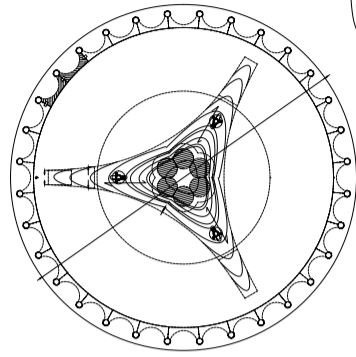
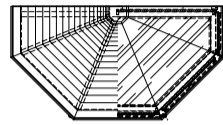
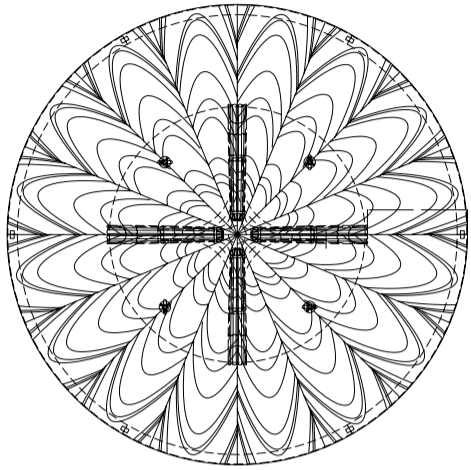
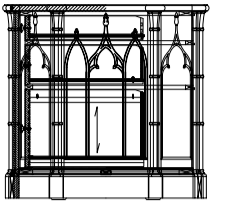
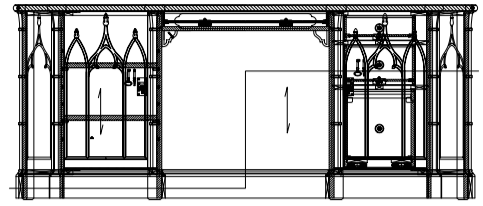
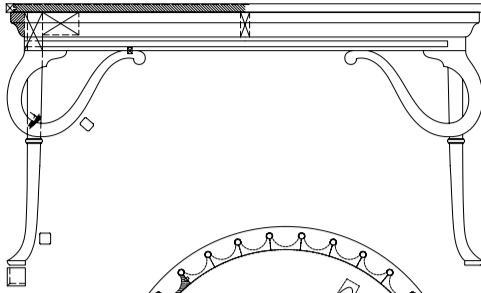
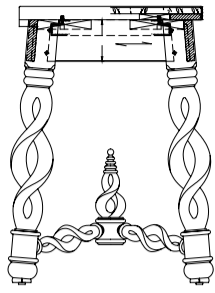
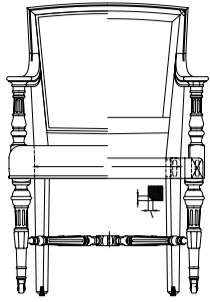
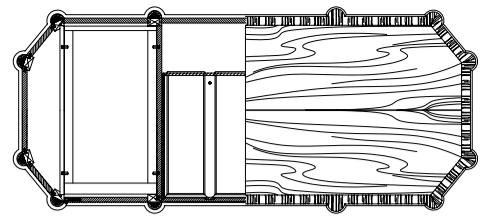
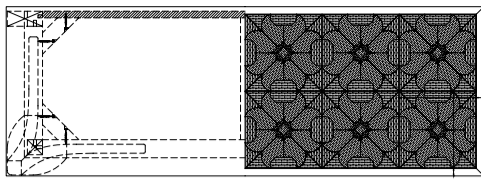
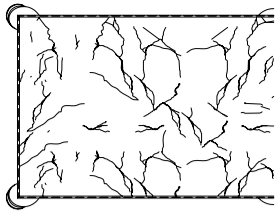
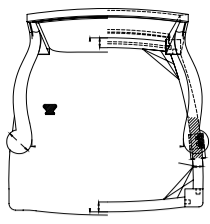

WILLIAM YEOWARD

270 KINGS ROAD LONDON SW3 5AW

enquiries@williamyeoward.com +44 (0) 20 7349 7828

williamyeoward.com